

内容详见附页

说明： * V1 * 骑马钉装订，中英文反转装 * 尺寸：410(L)x288(W)mm * 材料：80g书写纸，双面印刷 * 颜色及其它详见电子文档 * 请送样品确认。	作废	_____
	作废	_____
	作废	_____
	作废	_____
	作废	_____

日期	20-11-26	名称	美国KAT KT-100贴DM-1X说明书		料号		版本	V1	
制图	郑敬轩	文件名	美国KAT KT-100贴DM-1X说明书.cdr		光盘号	_____	材料	80g书写纸	
内容审核	邵剑锋	视角	_____	单位	毫米(mm)	颜色		图号	
标准化		 深圳市蔚科电子科技有限公司 CHERUB TECHNOLOGY COMPANY LIMITED				尺寸公差	±1.5mm	密级	普通
批准						第(1)页/共(27)页			

User Manual

KAT

KT-100

PORTABLE DIGITAL DRUM KIT

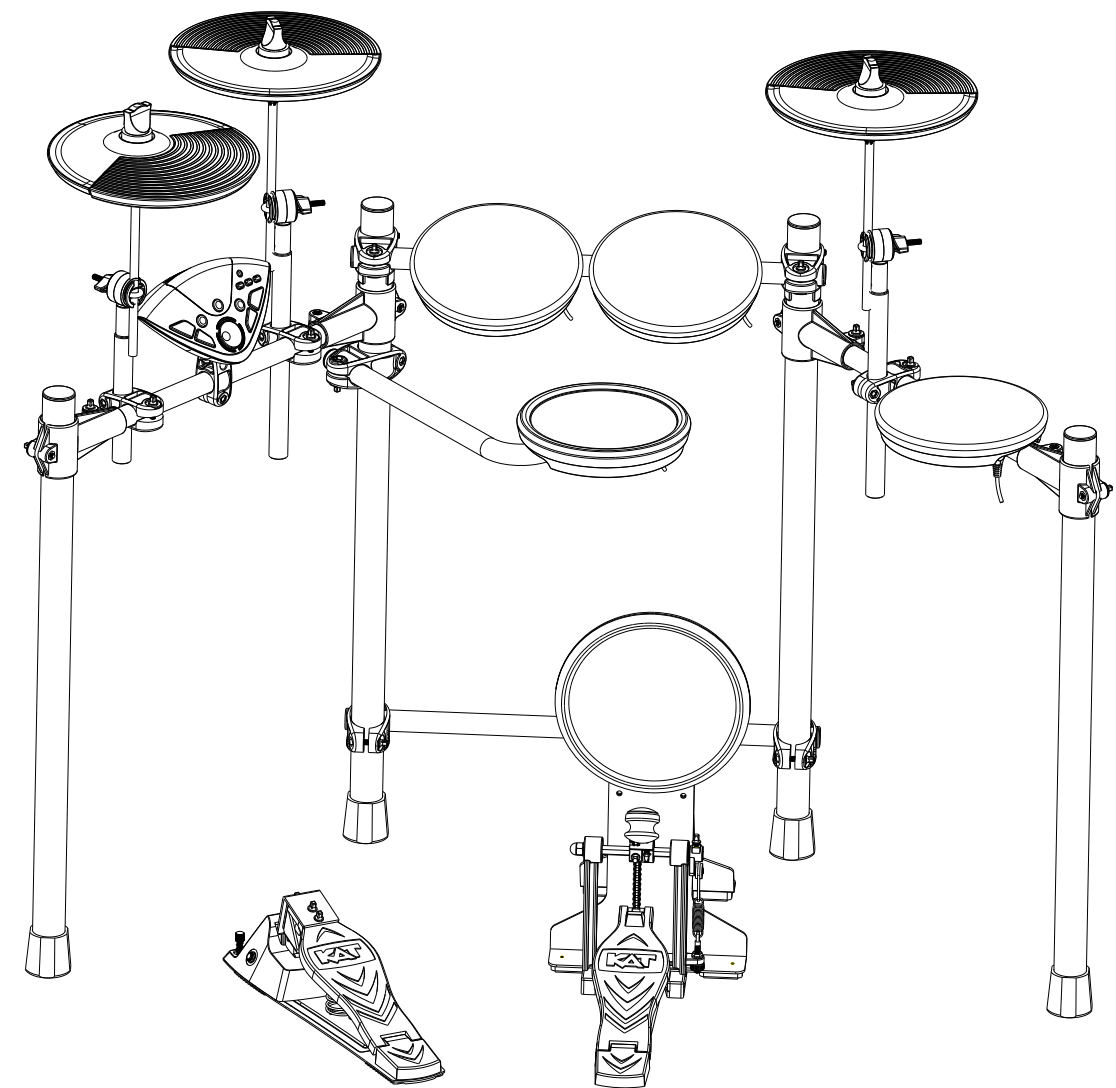

THE FCC REGULATION WARNING (for U.S.A.)

This equipment has been tested and found to comply with the limits for a Class B digital device, pursuant to Part 15 of the FCC Rules. These limits are designed to provide reasonable protection against harmful interference in a residential installation. This equipment generates, uses, and can radiate radio frequency energy and, if not installed and used in accordance with the instructions, may cause harmful interference to radio communications. However, there is no guarantee that interference will not occur in a particular installation. If this equipment does cause harmful interference to radio or television reception, which can be determined by turning the equipment off and on, the user is encouraged to try to correct the interference by one or more of the following measures:

- Reorient or relocate the receiving antenna.
- Increase the separation between the equipment and receiver.
- Connect the equipment into an outlet on a circuit different from that to which the receiver is connected.
- Consult the dealer or an experienced radio/TV technician for help.





Made in China

USING THE UNIT SAFELY

INSTRUCTIONS FOR THE PREVENTION OF FIRE, ELECTRIC SHOCK, OR INJURY TO PERSONS

About ⚠️ WARNING and ⚠️ CAUTION Notices About the Symbol

 WARNING	Used for instructions intended to alert the user to the risk of death or severe injury should the unit be used improperly.	 CAUTION	Used for instructions intended to alert the user to the risk of injury or material damage should the unit be used improperly. * Material damage refers to damage or other adverse effects caused with respect to the home and all its furnishings, as well to domestic animals or pets.
--	--	--	--

ALWAYS OBSERVE THE FOLLOWING

⚠️ WARNING

- Before using this unit, make sure to read the instructions below and the Owners Manual.
- Do not open (or modify in any way) the unit or its AC adaptor.
- Do not attempt to repair the unit, or replace parts within it (except when this manual provides specific instructions directing you to do so). Refer all servicing to your retailer, the nearest Service Center.
- Never use or store the unit in places that are: Subject to temperature extremes (e.g., direct sunlight in an enclosed vehicle, near a heating duct, on top of heat-generating equipment); or are Damp (e.g., baths, washrooms, on wet floors); or Are Humid; or Are Exposed to rain; or Are Dusty; or Are Subject to high levels of vibration.
- This unit may be installed on a stand using a Clamp.
- When installing the unit on a stand with a clamp, the stand must not be placed in an unstable location or on an incline, but in a level and stable position. Even if a stand is not used, make sure that the unit is placed in a stable location.

⚠️ WARNING

- Be sure to use only the AC adaptor supplied with the unit. Also, make sure the line voltage at the installation matches the input voltage specified on the AC adaptors body. Other AC adaptors may use a different polarity, or be designed for a different voltage, so their use could result in damage, malfunction, or electric shock.
- Do not excessively twist or bend the power cord, nor place heavy objects on it. Doing so can damage the cord, producing severed elements and short circuits. Damaged cords are fire and shock Hazards!
- This unit, either alone or in combination with an amplifier and headphones or speakers, may be capable of producing sound levels that could cause permanent hearing loss. Do not operate for a long period of time at a high volume level, or at a level that is uncomfortable. If you experience any hearing loss or ringing in the ears, you should immediately stop using the unit, and consult an Audiologist.
- Do not allow any objects (e.g., flammable material, coins, pins); or liquids of any kind (water, soft drinks, etc.) to penetrate the unit.

⚠️ WARNING

- Immediately turn the power off, remove the AC adaptor from the outlet, and request servicing by your retailer, the nearest Service Center.

The AC adaptor or the power-supply cord has been damaged; or
If smoke or an unusual odor occurs
Objects have fallen into, or liquid has been spilled onto the unit; or
The unit has been exposed to rain (or otherwise has become wet); or
The unit does not appear to operate normally or exhibits a marked change in performance.

- In households with small children, an adult should provide supervision until the child is capable of following all the rules essential for the safe operation of the unit.

- Protect the unit from strong impact. (Do not drop it!)

- Do not force the units power-supply cord to share an outlet with an unreasonable number of other devices. Be especially careful when using extension cords the total power used by all devices you have connected to the extension cords outlet must never exceed the power rating (watts/amperes) for the extension cord. Excessive loads can cause the insulation on the cord to heat up and eventually melt through.

- Before using the unit in a foreign country, consult with your retailer, the nearest Service Center.

⚠️ CAUTION

- The unit and the AC adaptor should be located so their location or position does not interfere with their proper ventilation.
- Always grasp only the output plug or the body of the AC adaptor when plugging into, or unplugging from, this unit or an outlet.
- Any accumulation of dust between the AC adaptor and the power outlet can result in poor insulation and lead to fire. Periodically wipe away such dust with a dry cloth. Also, disconnect the power plug from the power outlet whenever the unit is to remain unused for an extended period of time.
- Try to prevent cords and cables from becoming entangled. Also, all cords and cables should be placed so they are out of the reach of children.
- Never climb on top of, nor place heavy objects on the unit.
- Never handle the AC adaptor body, or its output plugs, with wet hands when plugging into, or unplugging from, an outlet or this unit.
- If you need to move the instrument, take note of the precautions listed below. Make sure to have a firm grip, to protect yourself from injury and the instrument from damage.
Check to make sure that the clamp that fixes the unit to the stand has not become loose. Fasten them again securely whenever you notice any loosening.
Disconnect the power cord.
Disconnect all cords coming from external devices.
- Before cleaning the unit, turn off the power and unplug the AC adaptor from the outlet.
- Whenever you suspect the possibility of lightning in your area, disconnect the AC adaptor from the outlet.
- Should you remove security screws, make sure to put them in a safe place out of children's reach, so there is no chance of them being swallowed accidentally.

CONTENTS

FAST INSTALLATION GUIDE.....	04
PANEL AND INTERFACE.....	07
CONNECTION.....	08
SCREEN DISPLAY.....	09
READY TO PLAY.....	10
MODE SELECTION OPERATION.....	13
DRUM KIT OPERATION.....	14
METRONOME TEMPO FUNCION.....	15
COACH FUNTION.....	16
PRACTICING WITH SONG.....	19
RECORDING.....	20
ONEKNOB EFFECT.....	21
SPECIFICATIONS.....	21
MIDI IMPLEMENTATION.....	22
DRUM SET NAME.....	22

ASSEMBLY DIAGRAM

Install different part

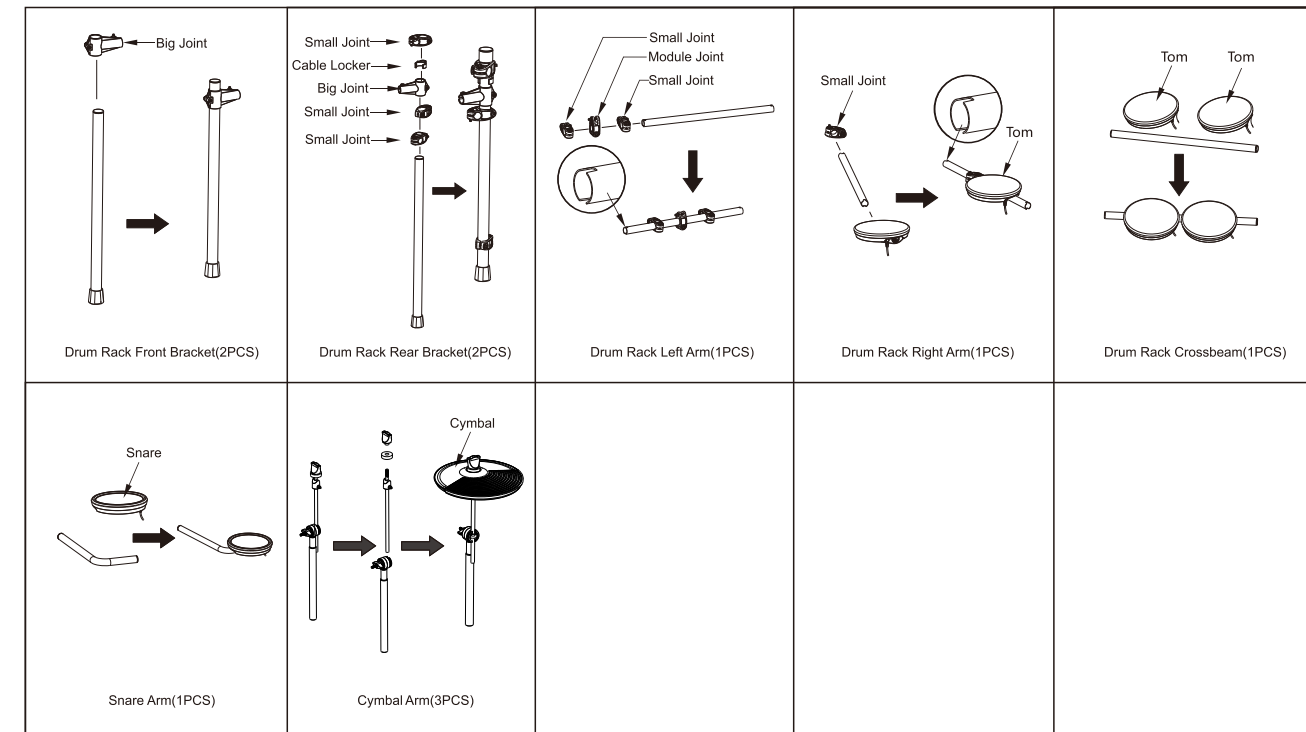

Final assembly

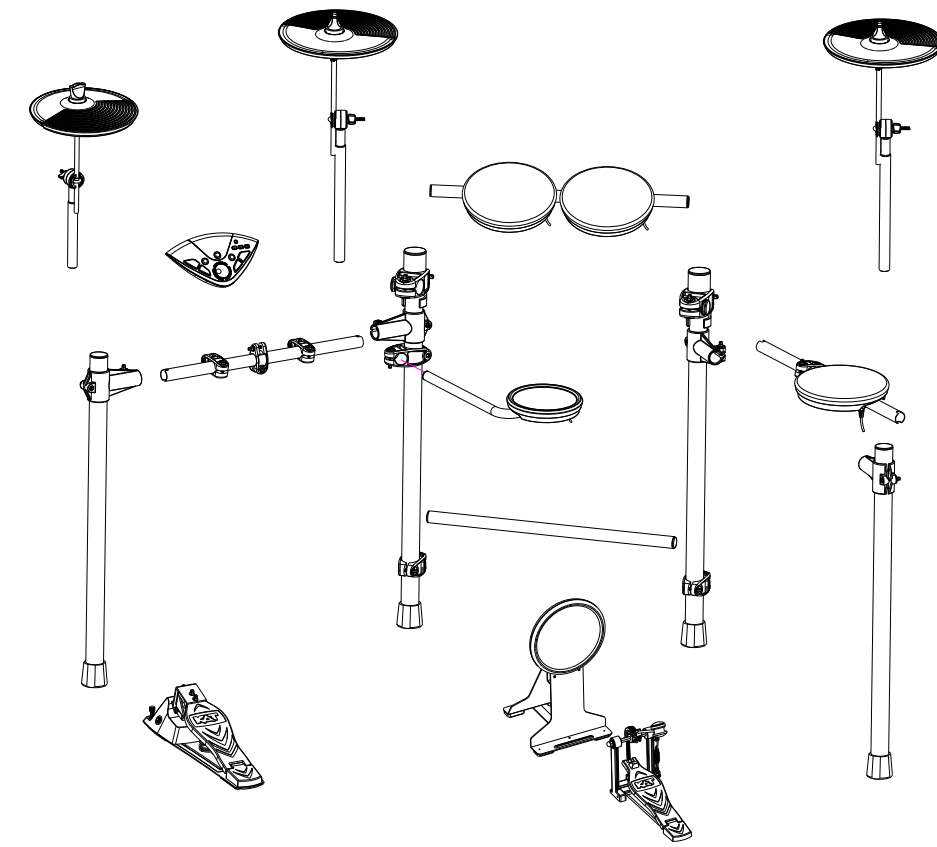

NOTE : Hi-hat control pedal and kick pedal are different; please check the label on the rear side before setting up the drum set.

Finish

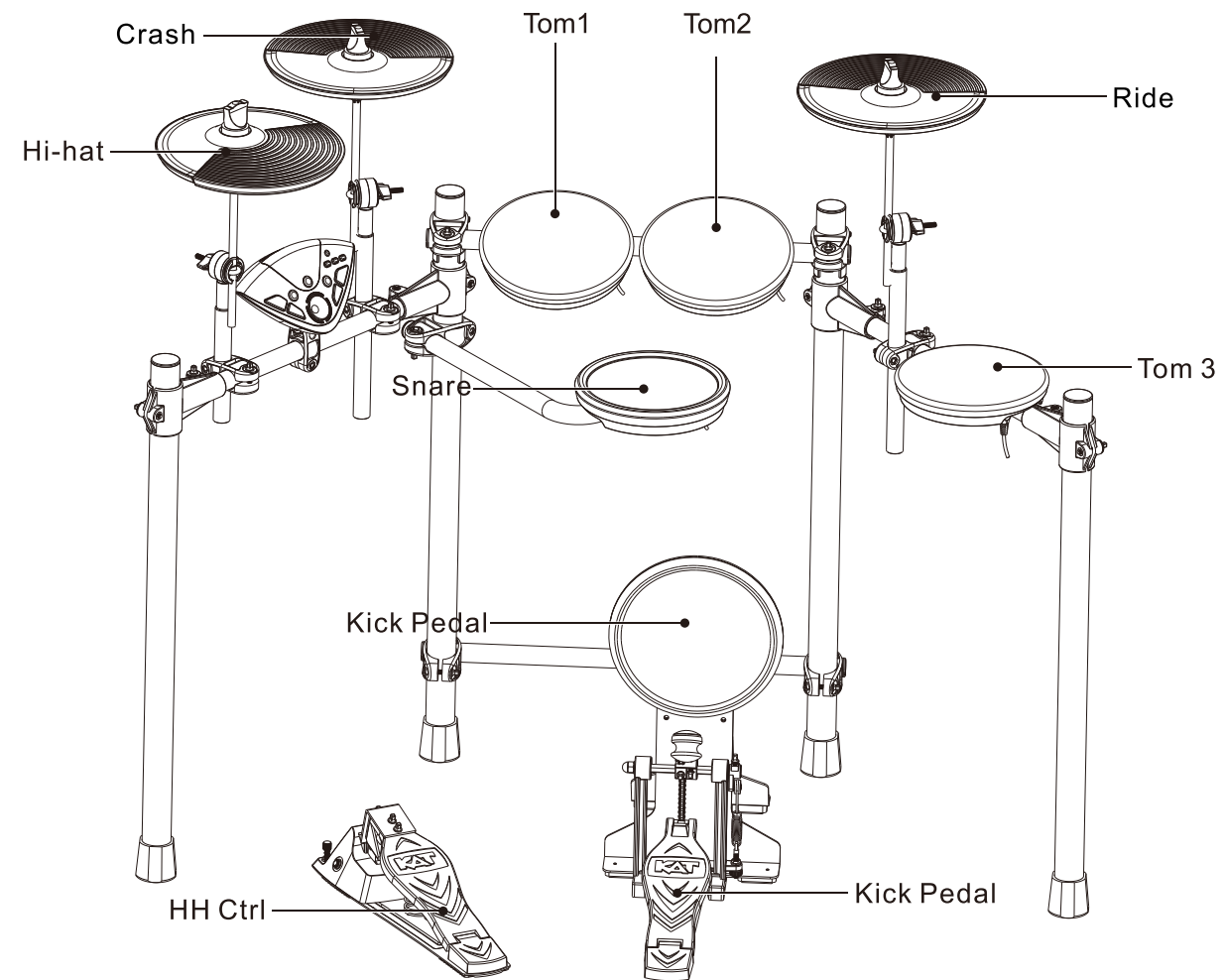

Connecting Data Cable

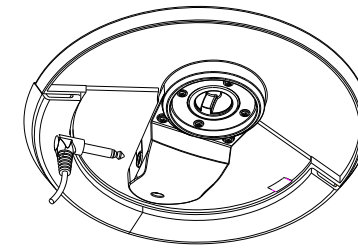

Connecting Cymbal

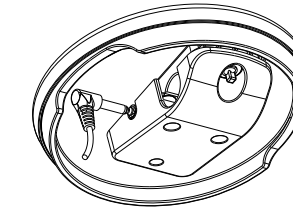

Connecting Drum Pad

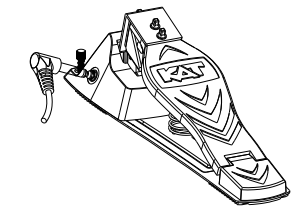

Connecting Pedal

Data Cable and Component relationship

Data Cable	Component
Gray mono cable	Kick
Blue mono cable	Hi-hat control
White two-channel cable	Hi-hat
Red two-channel cable	Crash
Green two-channel cable	Ride
Black mono cable	Tom3
Purple mono cable	Tom2
Orange mono cable	Tom1
Yellow two-channel cable	Snare

Fasten cables

Please fasten all cables with the provided cable clips as show in the below illustration.

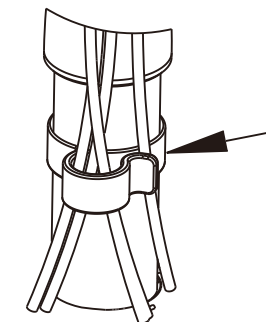

PANEL AND INTERFACE



1. Power Button

Turning ON/OFF KT-100.

2. Volume button

Press -+Volume button to adjust the pad's volume.

3. Drum Off button

Turn on or off demo songs.

4. REC button

Press REC to enter recording function.

5. Play button

Play/ Stop recording or demo songs.

6. + - button

Press +- to switch drum kits or adjust the pad's parameter.

7. OneKonb coder

To change or adjust effect.

8. SEL button

Press SEL to select modes which included four modes.

9. Effect light

Display current effect.

10. TAP Button

Press the TAP key to pick up the current speed.

11. Metronome Button

Press the Metronome button to start or stop the metronome mode or the coach mode.

12. USB

connect to computer.

13. DC IN Jack

Connect the 9V DC adaptor here.

14. AUX IN Jack

For connecting an external audio source such as MP3 or phone player.

15. PHONES jack

Connect your stereophonic headphones.

16. OUTPUT jack

Output mono signal.

17. LED Display

Shows the drum kit number and metronome tempo etc.

18. Mode lights

Show the current operation mode.

CONNECTION

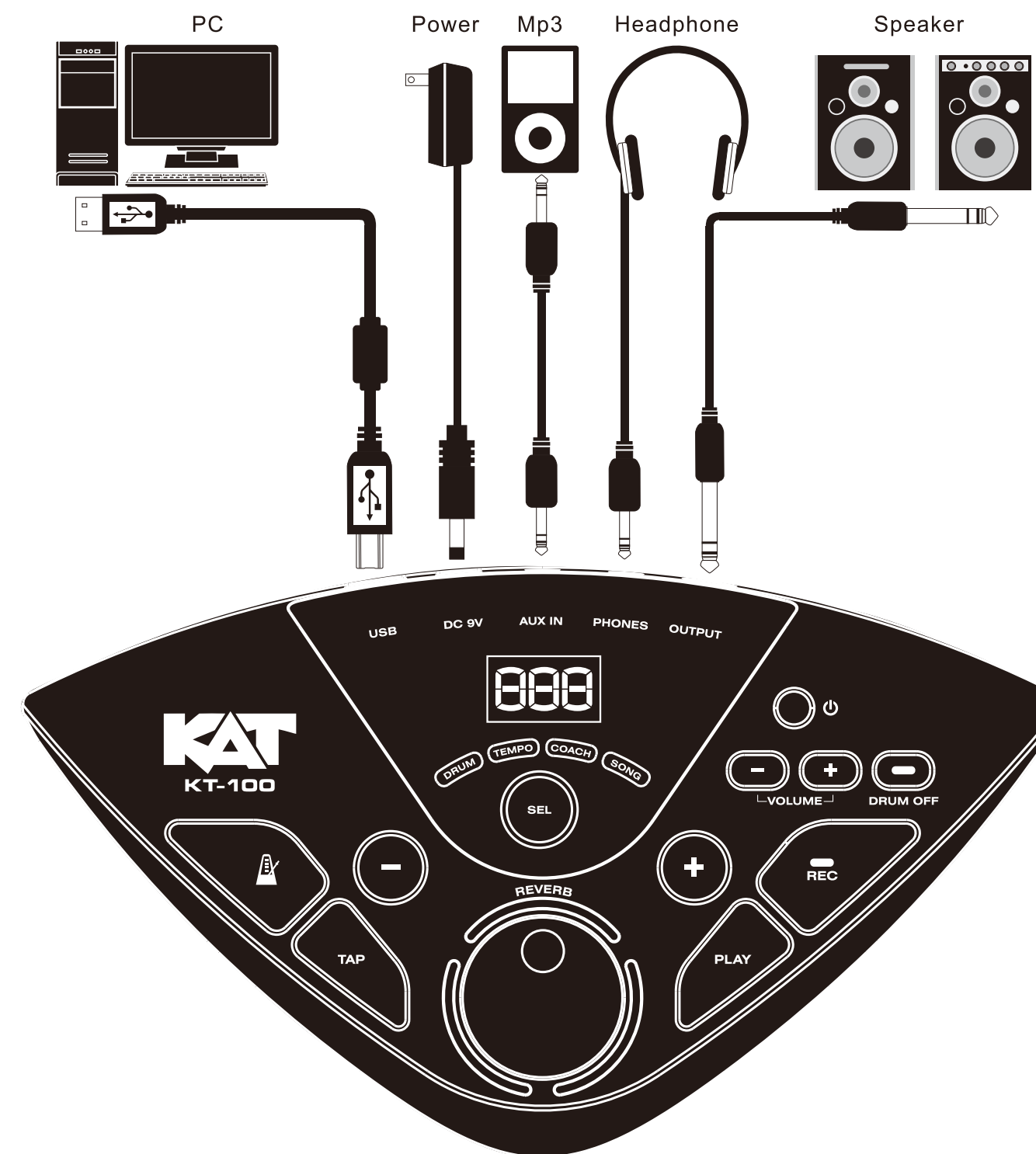

NOTE: To prevent malfunction and equipment failure, always turn down the volume, and turn off all the units before making any connections.

SCREEN DISPLAY

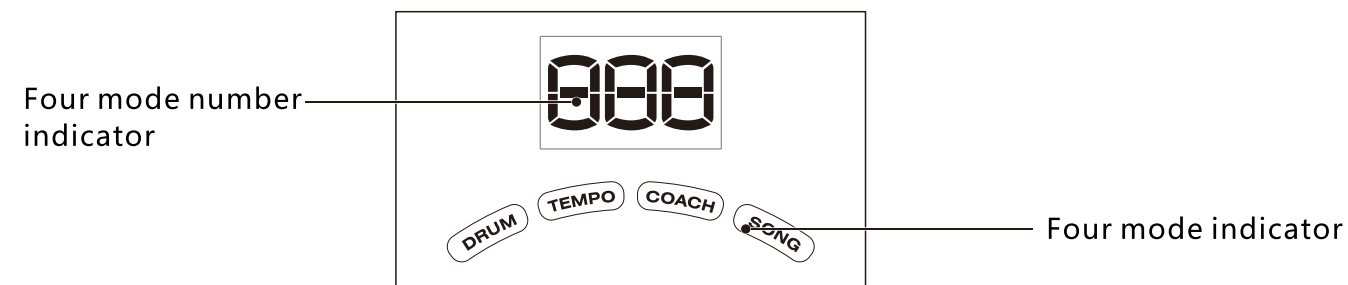

READY TO PLAY

Turn ON/OFF the Power

*Turn ON

1. Turn the VOL knob to the minimum.
2. Adjust the volume of the connected amp or audio system to the minimum.
3. Long press the power button to turn on.

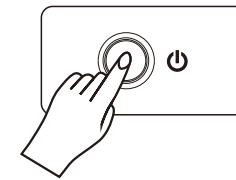

Turn on screen display



- * You may still hear some sound when the power is switched on, this is normal, and does not indicate a malfunction.

After power on, LCD will display drum kit number and name.

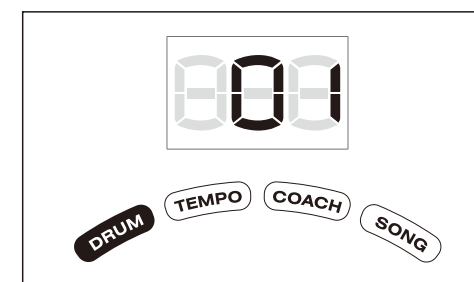

NOTE: 01 Drum Kit Number;
Drum Drum kit name.

4. While hitting a pad, gradually turn the VOL knob toward the right to adjust the volume.

KT-100 Playing method

* Snare

Head Shot

Hit only the head of the pad.

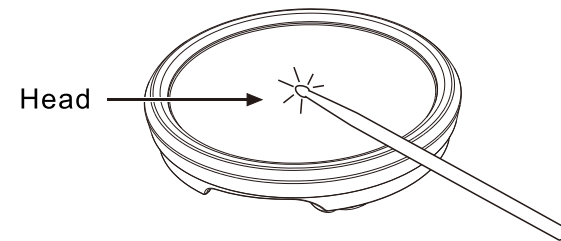

Open Rim Shot

Strike the rim of the pad.

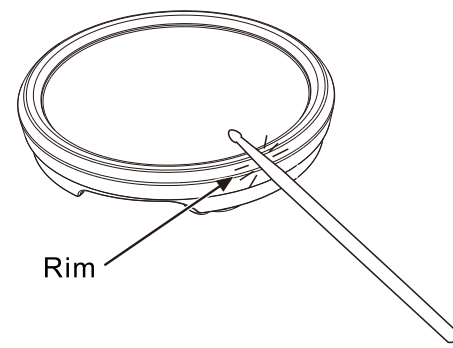

* Tom

Head Shot

Hit only the head of the pad.

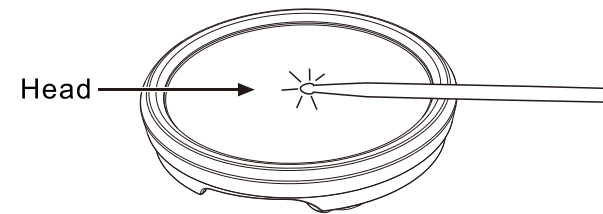

* Kick

Strike down the bottom drum pedal.

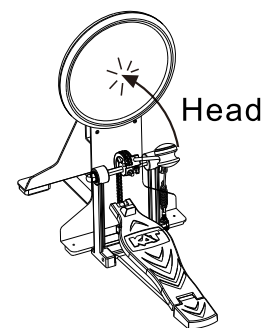

* Crash Ride

Bow Shot

Hit the middle area of the cymbal.

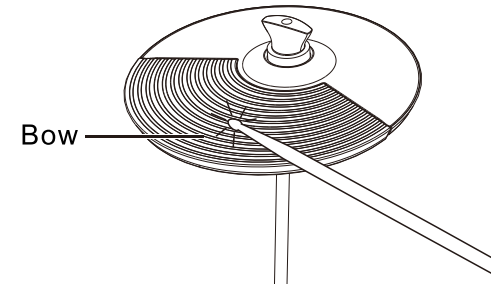

Edge Shot

Strike the edge with the shoulder of the stick.

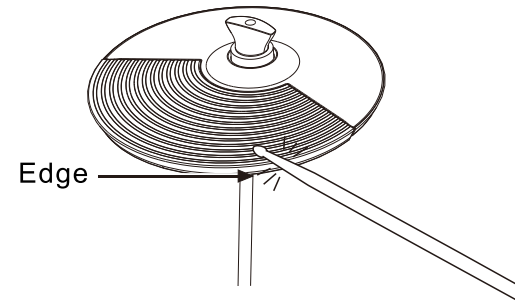

Choke a Cymbal

Pinch the cymbal's edge immediately after hitting the cymbal will choke the sound, just like with a real cymbal. The Choke function only works when you grasp in the sensing area.

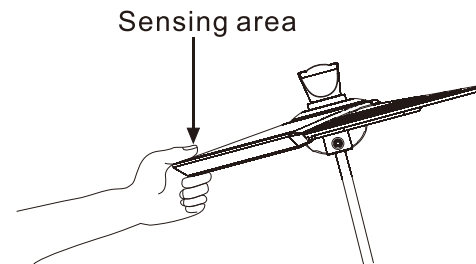

* Hi-hat

Open/Closed

The hi-hat sound will change smoothly between open and closed depending on pressure applied to the hi-hat control pedal. Foot closed and foot splash sounds are possible.

Bow Shot

Hit the middle area of the hi-hat pad.

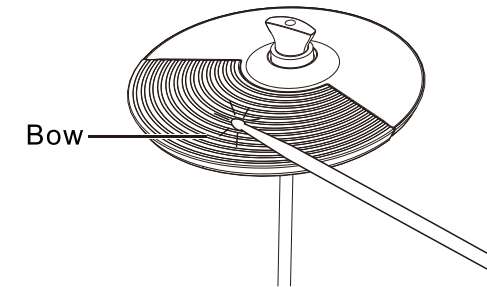

Choke a Cymbal

Choke the cymbal's edge with the hand immediately after hitting the cymbal will mute or choke the sound, just like with a real cymbal. The choke function only works when you grasp in the area.

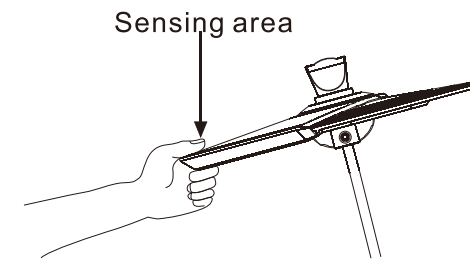

* Hi-Hat Control Pedal

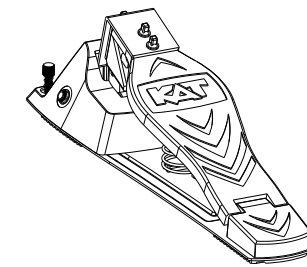

Open Hi-Hat

Strike the hi-hat without pressing the pedal.

Closed Hi-Hat

Strike the hi-hat with the pedal pressed.

MODE SELECTION OPERATION

1. Press [SEL] to choose DRUM, TEMPO, COACH, SONG mode, the selected mode would be lighted.

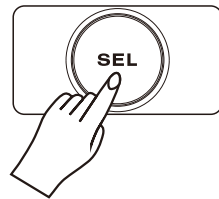

2. There are four picture show four modes : DRUM, TEMPO, COACH, SONG.



DRUM



TEMPO

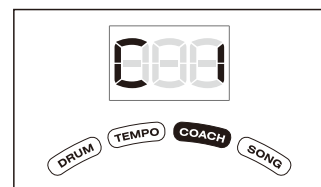

COACH

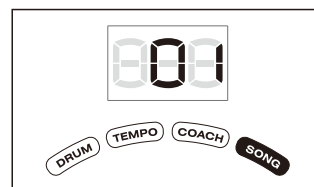

SONG

DRUM KIT OPERATION

Selecting a Drum Kit

When you select DRUM mode, the display shows:

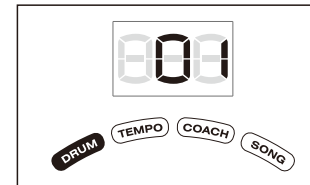

DRUM

1. Press the [-] [+] buttons to select a drum kit.

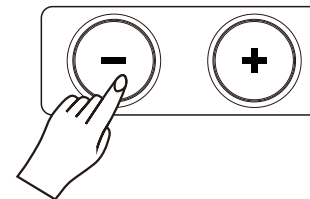

2. There are 20 drum kits in DRUM mode, from number 01 to 20.

Adjusting the Pad Sensitivity and changing MIDI Note Number of the Pad

1. Press and hold the [A1] button to enter the DRUM parameter adjustment. The DRUM mode indicator and the "Metronome" indicator flash.

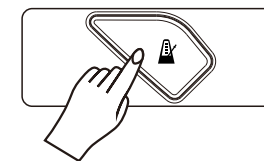

2. Press the [SEL] key to select the parameter you want to adjust, and press the [-] and [+] keys to adjust the parameter value.

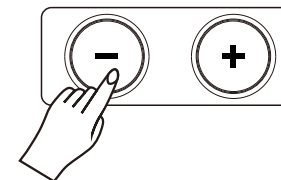

3. Press [-] and [+] keys to adjust the parameter value. The adjustable range is as follows.

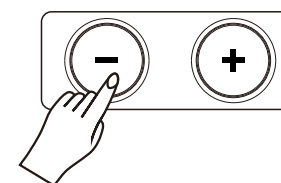

Parameter	Range
anti-crosstalk[C32]	0 - 80
MIDI Channel[P10]	1 - 16
Sensitivity	S0.1 - S3.2
RIM gain	Display r—without rim parameters. Display r1.0 with rim, range r0.1-r3.2

4. The value of the pads from 0.1-3.2, you can press [-] [+] buttons to choose different midi note.

Drum name	Midi note
Kick	36
Snare	38
Snare rim	40
Tom1	48
Tom2	45
Tom3	41
Ride bow	51
Ride edge	59
Crash bow	49
Crash edge	55
Hihat open	46
Hihat closed	42
Hihat pedal	44

METRONOME TEMPO FUNCTION

Metronome mode

1. Press [SEL] to choose TEMPO mode, the display shows:



2. In TEMPO mode, press [-][+] button or [TAP] button to adjust TEMPO.

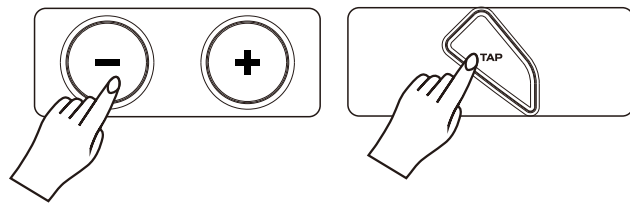

3. Press [M] button to turn ON/OFF metronome.

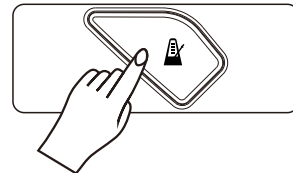

Screen Display	Value	Description
	40-240	Setting the tempo of metronome (And the tempo of demo songs)

Parameter editing

1. In Tempo mode, long-press the [M] Metronome button. The metronome sounds.

2. Use the [SEL] button to select the item (parameter) that you want to change, and use the [-][+] buttons to change its settings.

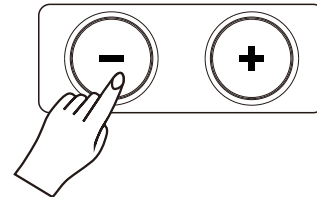

b 1	Adjust Beat value
r 4	Adjust Rhythm type
L 0	Adjust the volume

3. Press [M] button to complete the settings.

Parameter	Display	Explanation
Beats	b 1 - b 9	Sets the number of beats
Rhythm type	r 4 (Quarter notes)	Sets the beat unit
	r 8 (Eighth notes)	
	r 16 (Sixteenth notes)	
Volume	L 0 - L 10	Sets the volume

COACH FUNCTION

1. Use the [SEL] button to select Coach Mode.

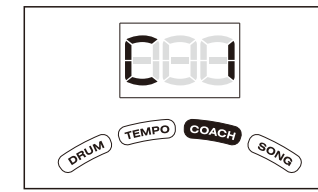

2. Press the [-][+] buttons to select a practice menu C1-C6.

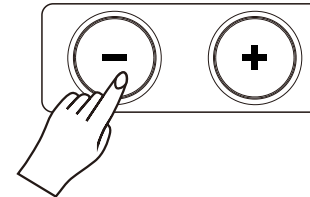

* (C 1) Time Check (Easy)

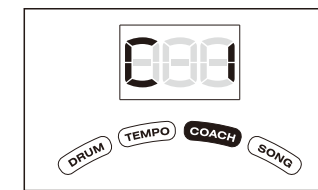

Long-press the [M] button to enter the C1 setting mode.

When you enter the C1 setting mode, the display shows:

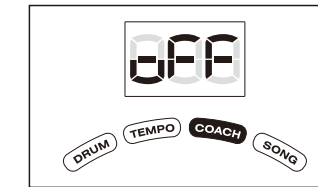

1. Press the [-][+] buttons to change the value.

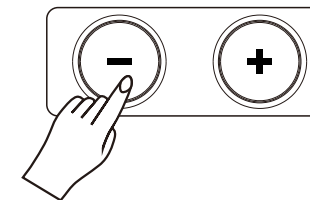

Display	Explanation
	No scoring
	Specify the number of measures that are scored. The score result is shown in the display.
.....	
	*A two-measure count-in is inserted when you start.

2. Press [M] button to start practicing. A two-measure count-in is inserted when you start.

3. Strike the pad in time with the metronome. The display will indicate whether your pad strikes match the beat sounded by the metronome.

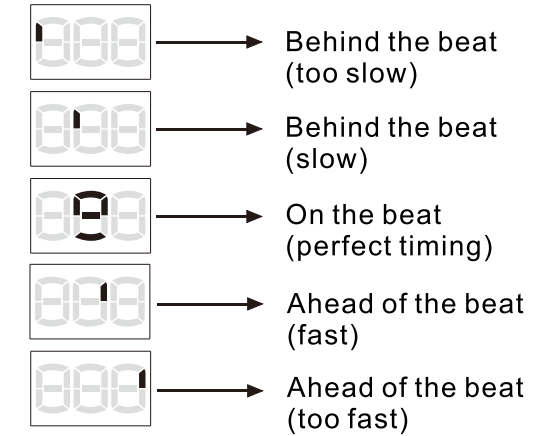

4. Time Check automatically ends, and the results will appear in the display.

* (C 2) Change up

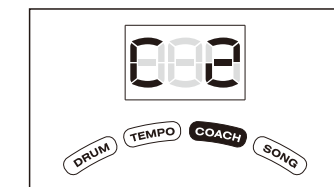

The rhythm type will change every two measures. Starting from half notes, the note values will gradually become shorter, and will then return to half notes; this change in rhythms will be repeated.

1. Press [M] button to start practicing.
2. Strike the pad in time with the metronome. The display shows the tempo while you practice.

* You can use the [-][+] buttons to adjust the tempo even while you practice.

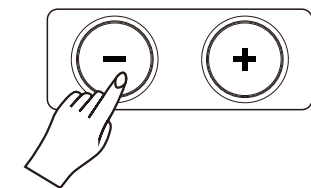

3. Press [M] button to return to the Coach Mode menu screen.

COACH FUNCTION

4. No parameter settings, original default rhythm is:



(r4 means Quarter notes, R8 means Eighth notes, r83 means Eighth note triplets, r16 means Sixteenth notes.)

5. Changing rhythm practice measures.

- Long press [] button, the light of Coach will flash.
- Press [-][+] buttons to change the value of measures.

Display	Explanation
	Initial setting: the rhythm of the metronome changes at intervals of four measures.
	The value of adjusting measure from 1 to 8.

* (C 3) Auto Up/Down

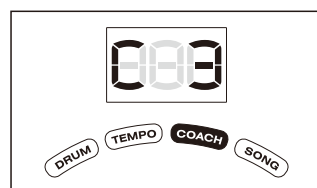

The metronome increases and decreases tempo over time, to help develop stamina and endurance. The tempo will increase in steps for each beat until the metronome reaches the upper limit, then the tempo will continue slowing down in steps until it reaches the initial tempo. This cycle will repeat.

- Press the [] metronome button to start practicing.
- Strike the pad in time with the metronome.
 - In initial setting, the default minimize is 100, the default maximize is 150.
 - While practicing, you can press the [-] button to specify the current tempo as the upper limit, it decrease at 10 per time, the minimum range from 40 to 140, when the current tempo as the lower limit(40); If you press the [-] button, the lower tempo limit return to 140.
 - While practicing, you can press the [+] button to specify the current tempo as the upper limit, it decrease at 10 per time, the maximum range from 40 to 140, when the current tempo as the upper limit (240) ; If you press the [+] button, the upper tempo limit return to 150.

In C3 mode, long press [] button to enter C3 setting mode, this display shows:



Specifying the pattern of rhythm change

- Long-press [] button, the light of coach will flash.
- Press the [-] [+] buttons to change the value.

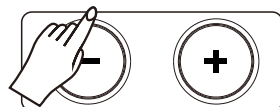

Display	Explanation
	The volume of the metronome changes at intervals of one measure.
	The volume of the metronome changes at intervals of two measures.
	For the first three measures, the metronome sounds at the specified volume; for the next measure, the volume is increased or reduced.
	For the first four measures, the metronome sounds at the specified volume; for the next measure, the volume is increased or reduced.

* (C 4) Quiet Count

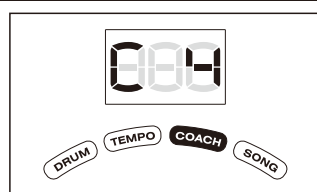

The practice will help you develop a good sense of time/tempo.

The metronome alternates between "sounding and not sounding" at every four measures, and the cycle will repeat.

- Press the [] button to start practicing.
- Strike the pad in time with the metronome.
 - The metronome sounds during the first few measures.
 - The metronome does not sound on subsequent measures. Continue striking the pads during this time.
 - The metronome sounds again, the value

COACH FUNCTION

indicates from 0-100 which you played at an accurate tempo.

*You can use the [-][+] buttons to adjust the tempo even while you practice.

- Press the [] button to return to the coach mode menu screen.



- Press [] button to return to the Coach mode menu screen.

- Initial setting: the metronome alternates between "sounding and not sounding" at every four measures.

Setting measures of mute practice

- Long press [] metronome button, the light of Coach will flash.

- Press [-][+] buttons to change the value of measures.

Display	Explanation
	Initial setting: The metronome alternates between "sounding and not sounding" at every four measures. The value of changing measure from 1 to 8.

* (C 5) Tempo Check



This menu lets you practice playing at a steady tempo without relying on the tempo sounded by the metronome.

- Press the metronome button to start practicing.
 - Strike the pad in time with the metronome. Please strike the pads at a constant tempo.
 - The more your tempo becomes accurate, the softer the metronome volume will become.
 - The metronome volume will increase if the tempo of your pad strikes begins to drift. The more your tempo drifts, the louder the metronome will become.
 - Strike the pads with an accurate timing that matches the tempo of the metronome.
- * You can use the [-][+] buttons to adjust the tempo even while you practice.
- * If the tempo of your strikes is significantly inaccurate, it may be impossible to precisely determine the amount of inaccuracy.

* (C 6) Stroke Balance

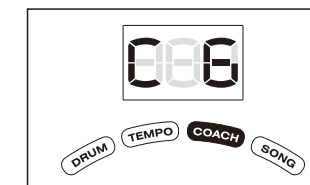

This practice lets you reduce the volume discrepancy between your right and left hands, so that the sound is more consistent. The display shows the strength of your strikes.

- Press the [] button to start practicing.
- Strike the pad in time with the metronome. The strength of your strikes on the pad is shown in the display.

*You can use the [-][+] buttons to adjust the tempo even while you practice.

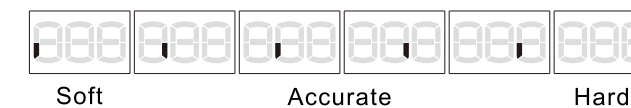

- Press the [] button to return to the coach mode menu screen.

PRACTICING ALONG WITH A SONG

Enter to SONG mode

Enter to SONG mode, the display shows:

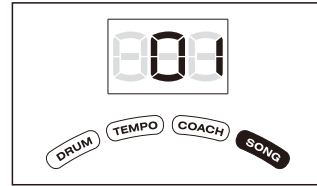

1. In the song mode, press [-] [+] buttons to select a song.

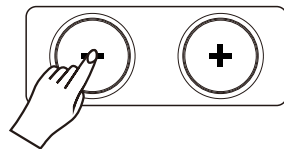

2. There are 10 practice songs in the SONG mode, the name from 01 to 10.
3. Press [PLAY] button to play Demo songs, press [DRUM OFF] button to remove the sound of drum.

SONG mode Parameter setting

Long press [] button to enter the settings of song, the light of song LED will flash, press [SEL] button to choose changing music volume or music tempo.

1. Press [-] [+] buttons to adjust the volume of music from L0 to L10.
2. Press [-] [+] buttons to adjust music tempo and tempo of metronome.



Set speed



Set volume

RECORDING

Press [REC] button, and the DM-1X will enter recording-standby mode, in the time, the light will be flashed. This picture shows as recording-standby mode situation, the screen light flash every 0.5 s. Press [PLAY] button to PLAYBACK the song which have been recorded.

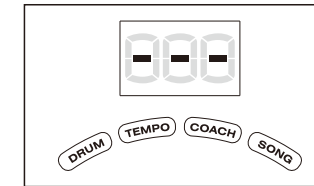

When start the recording, the display shows as followed picture. In recording mode, the screen light flashes every 0.5 s. To stop recording, press [REC] button again to stop recording.

When recording, if no drum signal input for more than 5s, it will stop recording and displays COMPLETE.

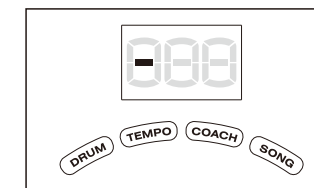

This picture shows the situation when you have completed the recording, press [PLAY] button to play recording song. Recording again it will automatically delete the existed recording song.

Press [REC] button to exit recording mode, recording song will save automatically and machine come back to DRUM mode.

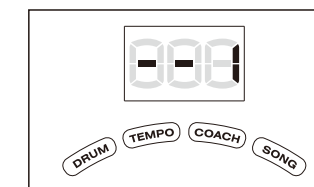

PLAYING WITH ONEKONB EFFECT

Use ONE KNOB to adjust the reverb

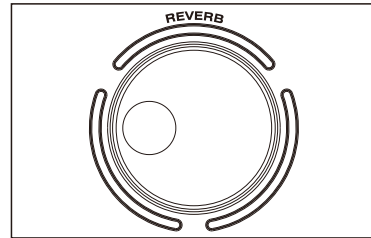

Reverb

Turn the dial to light up, every lighting area means a kind of reverb, the lighting area is larger, the reverb effect is stronger.

NOTE: The machine save settings automatically, press [] button and REC to turn on, the settings come back to initial value and the existed recording will be deleted.

SPECIFICATIONS

Display: LED display
 Drum kits: 20 kits (factory set)
 Recording: 1
 CLICK: adjust metronome sound, speed, tempo and volume
 Midi Function: USB-MIDI
 Effect types: Compress
 Jack: AUX-in, Power Jack, USB MIDI, OUTPUT, Earphone
 Trigger: 3 x Tom (Single), 1 Snare (double), 1 HI-Hat(double,) 1 crash(double) 1 ride(double)
 Power Supply: DC 9V Negative tip 145mA current draw (⊖⊕)
 Net Weight: 12.5KG

MIDI IMPLEMENTATION CHART

Function	Transmitted	Recognized	Remarked	
Basic default	10	10		
Channel changed	No	No		
Note	0-127	0-127		
Velocity:	Note on	Yes	Yes	
	Note off	No	Yes	
After Key's	No	No		
Touch Channel's	No	No		
Control change:	0	No	No	Bank select
	1	No	No	Modulation
	5	No	No	Portamento time
	7	No	No	Volume
	10	No	No	Pan
	11	No	No	Expression
	64	No	No	Sustain pedal
	65	No	No	Portamento on/off
	66	No	No	Sostenuto pedal
	67	No	No	Soft pedal
	120	No	No	All sound off
121	No	No	Reset all controllers	
123	No	No	All note off	
Program change	No	No		
System exclusive	No	No		

DRUM SET NAME

01	Standard	11	Rock
02	Studio	12	Flame
03	Nervous	13	Ancient
04	Rokokit	14	Drive
05	Jazz 1	15	Old
06	Jazz 2	16	Drumline
07	Blast	17	Tape 808
08	Sonor	18	Tape 909
09	Slamin	19	Dancehall
10	Metal	20	Folk Music